

Plantvoorbeelden

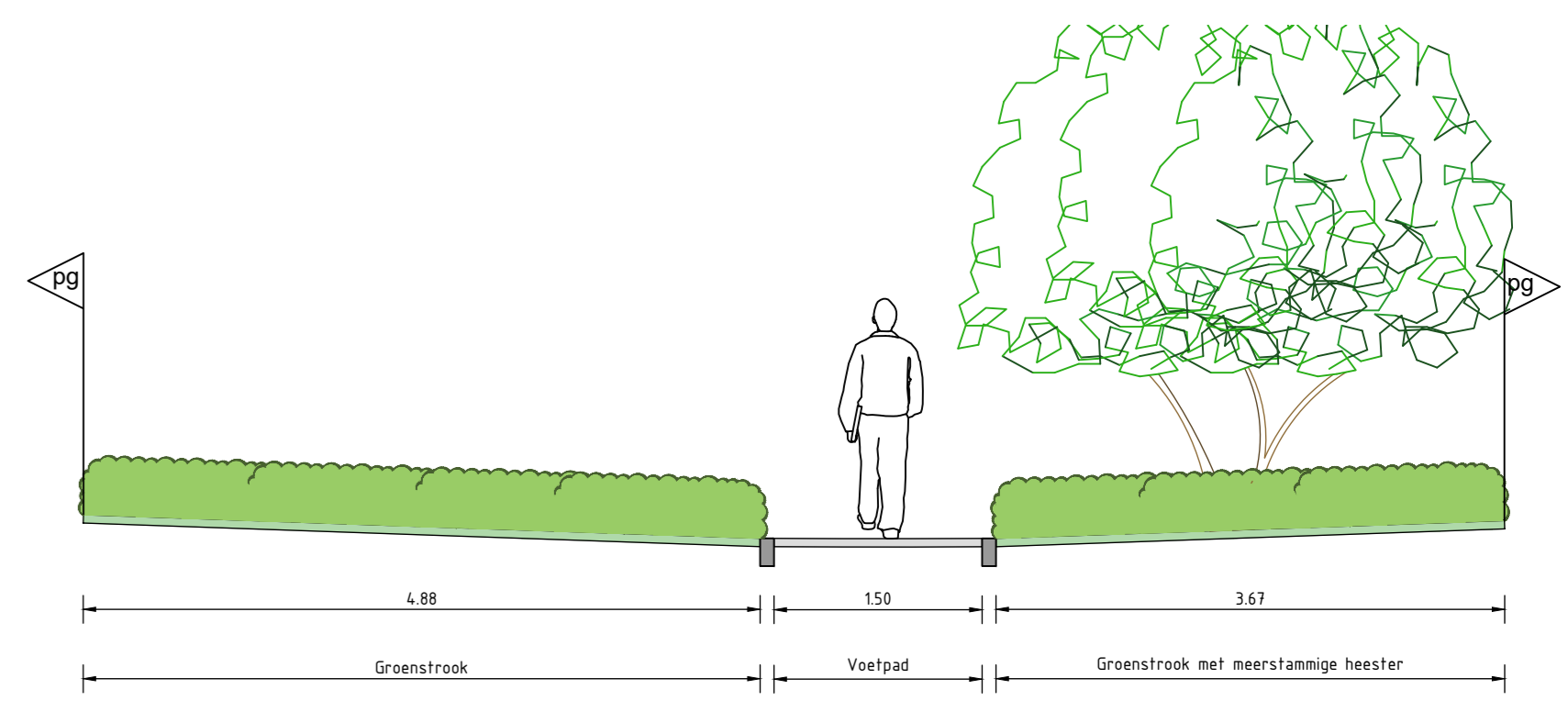

Principe profiel A-A  
Achterpad  
Schaal 1:50

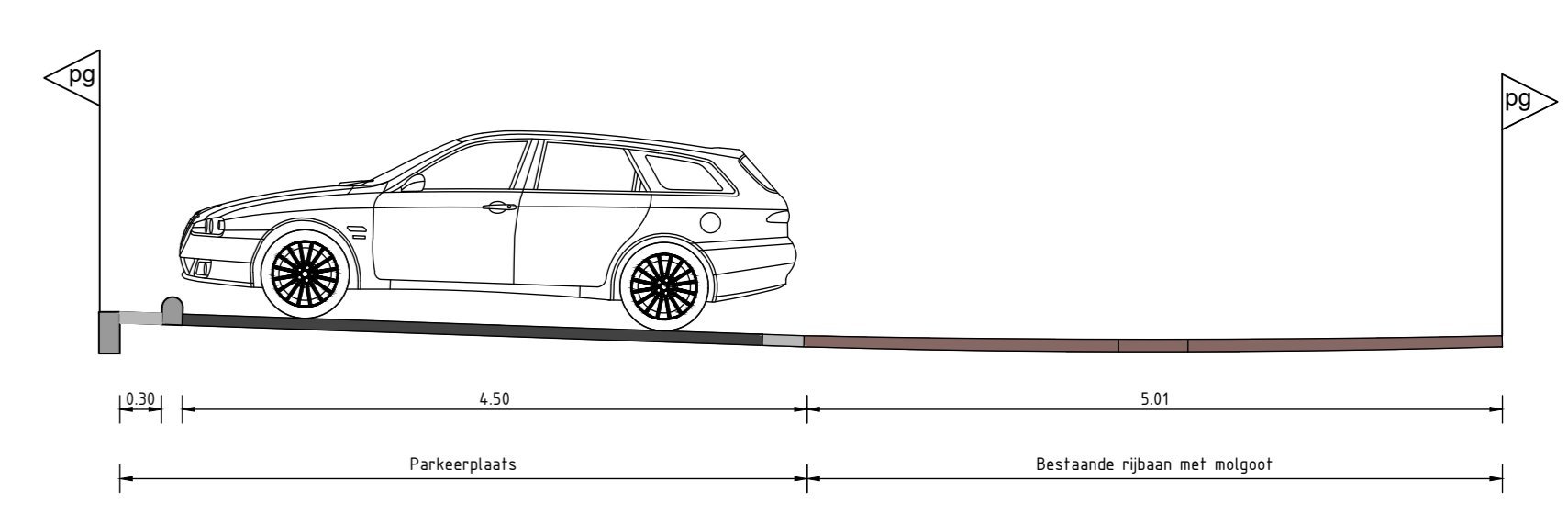

Principe profiel B-B  
Parkeerplaats  
Schaal 1:50

- Kadaster grens
- Bestaande situatie
- Bestaande bebouwing
- Werkgrens
- Voetpad
- Voetpad/Fietspad
- Toegangspad tot poorten
- Parkeerplaats
- Wadi
- Nieuw groenvak
- Stofbanden
- Nieuwe meerstammige heester
- Nieuwe boom
- Te handhaven boom

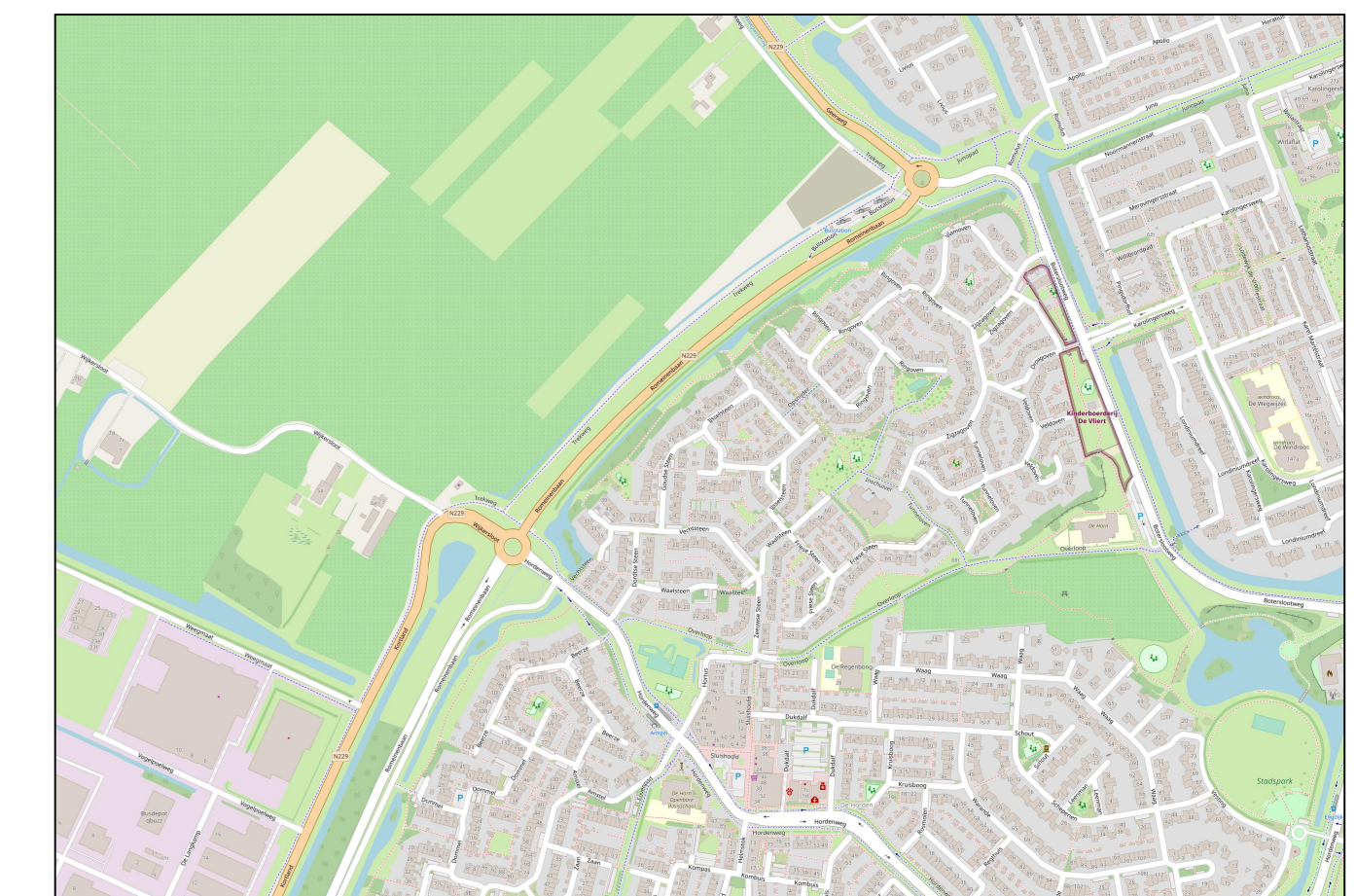

Opmerkingen:

Maten in meters tenzij anders vermeld

Hoogte maten in meters t.o.v. N.A.P.

DO	25-06-2023	Concept				
REV.	DATA	OMSCHRIJVING REVISIE	GEWIS	REVISIE	REVISIE	REVISIE

OPDRACGEVER: Gemeente Wijk bij Duurstede

PROJECT: Vervangingsproject Opsnijder  
Te Wijk bij Duurstede

ONDERDEEL: Ruimtelijke inrichting  
Voorlopig Ontwerp

VERSIE	2.0	PROJEKTNR	INFR230228
DATA	21.06.2023	GECONTROLEERD	RIJN
GETEKEND	IK	GEZEN	RIJN
STATUS	CONCEPT	SCHAAL	1:200
BLADNR		FORMAAT	A0



iv-infra b.v.  
Fulltoeren 30  
3439 NE Nieuwegein  
Nederland  
T +31 (0) 487 33300  
www.iv-infra.nl